



*LED's illuminate your project!*

[www.ledtechnic.be](http://www.ledtechnic.be)

**Product datasheet**



# RGB LEDline



## 1. Available sizes

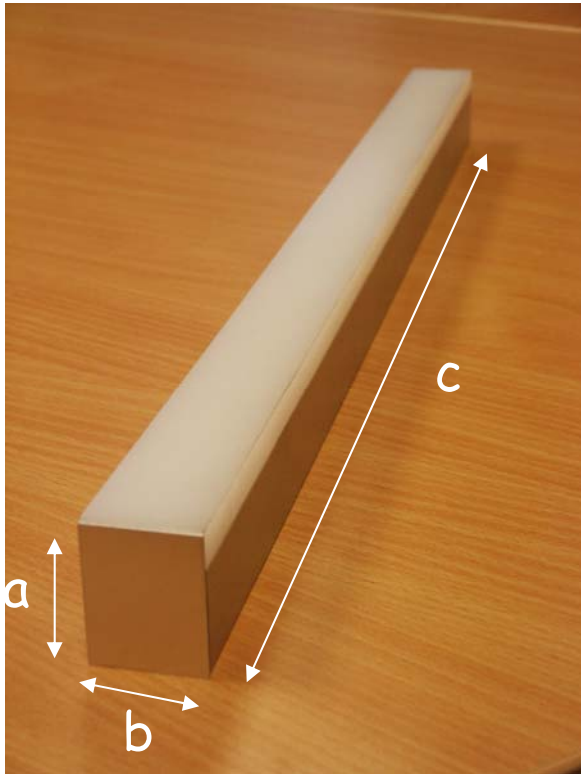

a	b	c	kg
40mm	30mm	500mm	0,6
40mm	30mm	1000mm	1,2

For other lengths, please contact us.

### Mechanical strength test:

- ✓ Impact: 4xIK10 (80Joule)
- ✓ Loadtest: tested at 60kg/cm<sup>2</sup>

## 2. Supply leads on RGB LEDline



c	d
500mm	250mm
1000mm	750mm

### 3. RGB-driver

Acts as an DMX to RGB-LEDline interface.



Cable length	kg
504mm	0,1
1004mm	0,1

DMX address programmable with RDM<sup>1</sup> use of RAD<sup>2</sup> device.  
The DMX driver 'clicks' in the LEDline extrusion.

<sup>1</sup> Remote Device Management

<sup>2</sup> Remote Addressing Device

#### 4. LEDline + RGB-driver

##### Electrical Specifications:

<b>Voltage</b>	24V DC	
<b>Maximum Current<sup>3</sup></b>	500mm	0,37A
	1000mm	0,70A
<b>IP</b>	68	
<b>DMX adress<sup>4</sup></b>	001	

#### 5. Wiring (input and output of RGB driver)

Color Code	
Brown	+24V DC
White	DMX+
Blue	DMX-
Black	Ground (for DMX and Power supply)

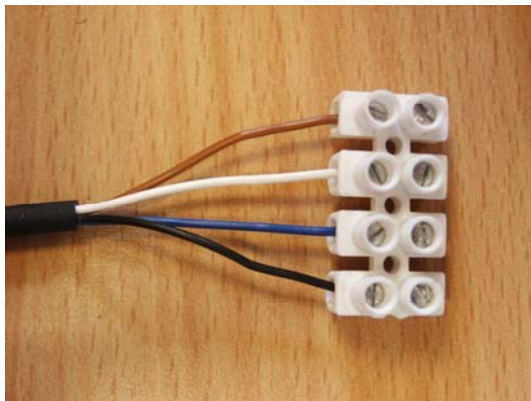

<sup>3</sup> R:100% G:100% B:100%

<sup>4</sup> Can be changed with RAD

## 6. Wiring diagrams

### 6.1. Connections between LEDlines and RGB-drivers

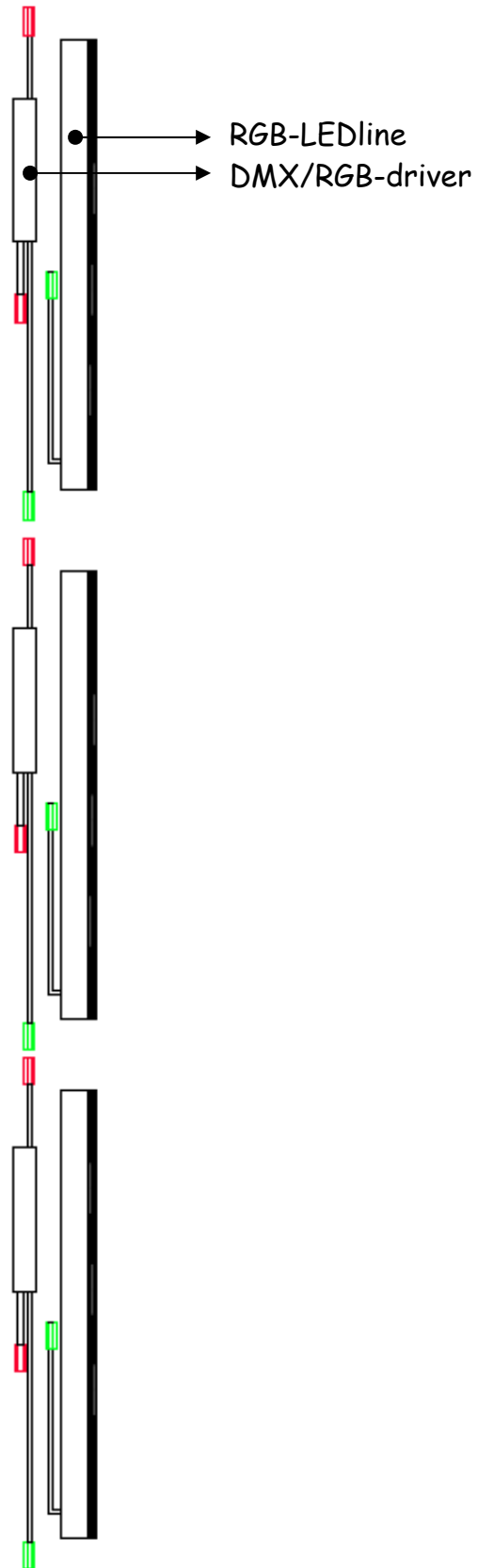

### 6.2. Connections between multiple LEDstrings ( Splitter boxes separated )

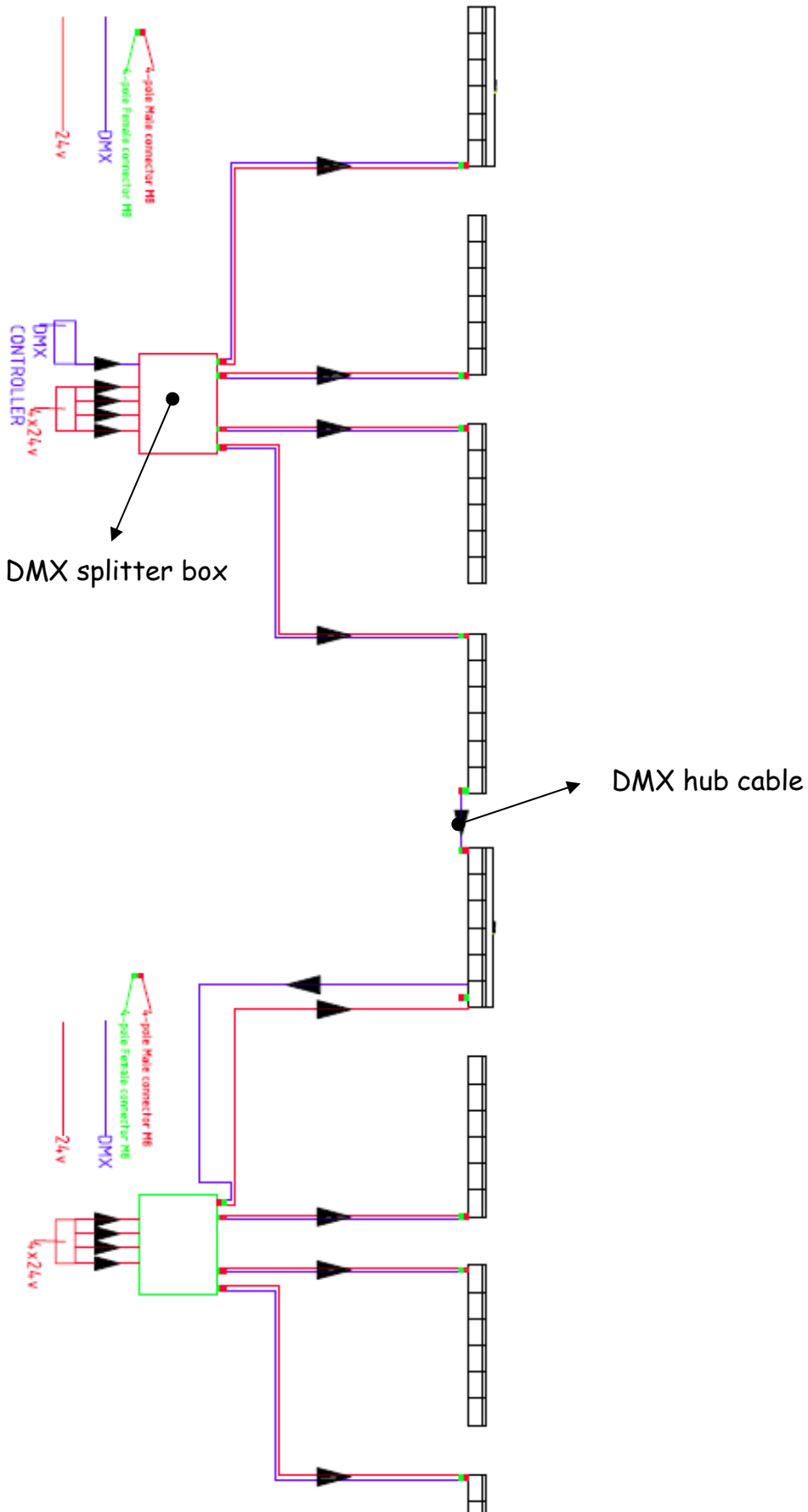

### 6.3. Connections between multiple LEDstrings ( Splitter boxes together )

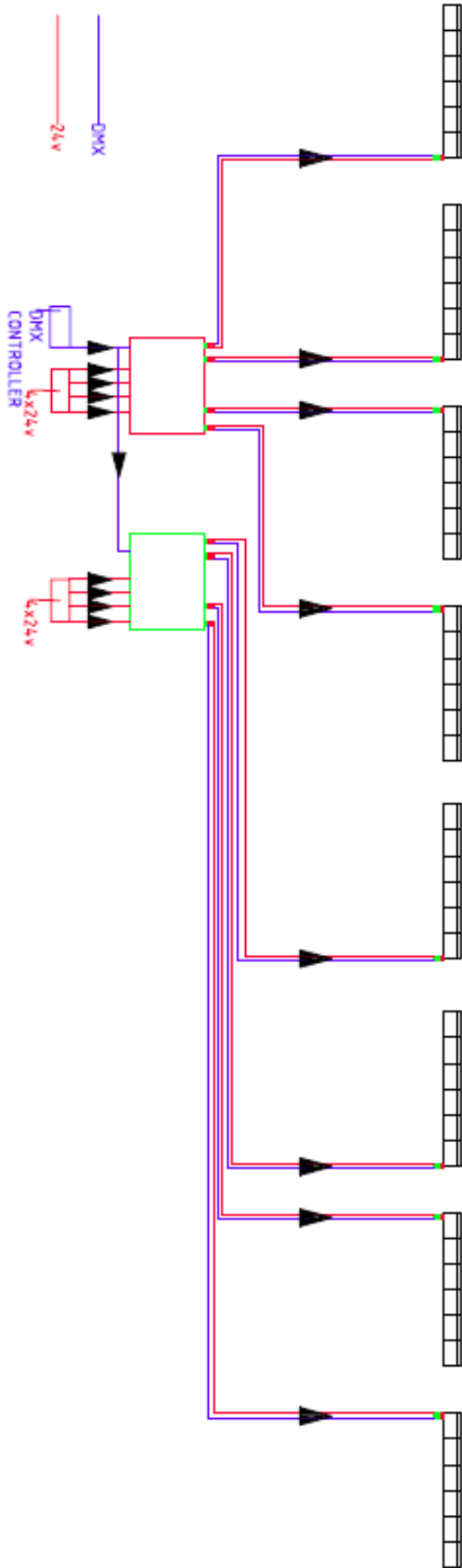

## 7. General wiring diagram

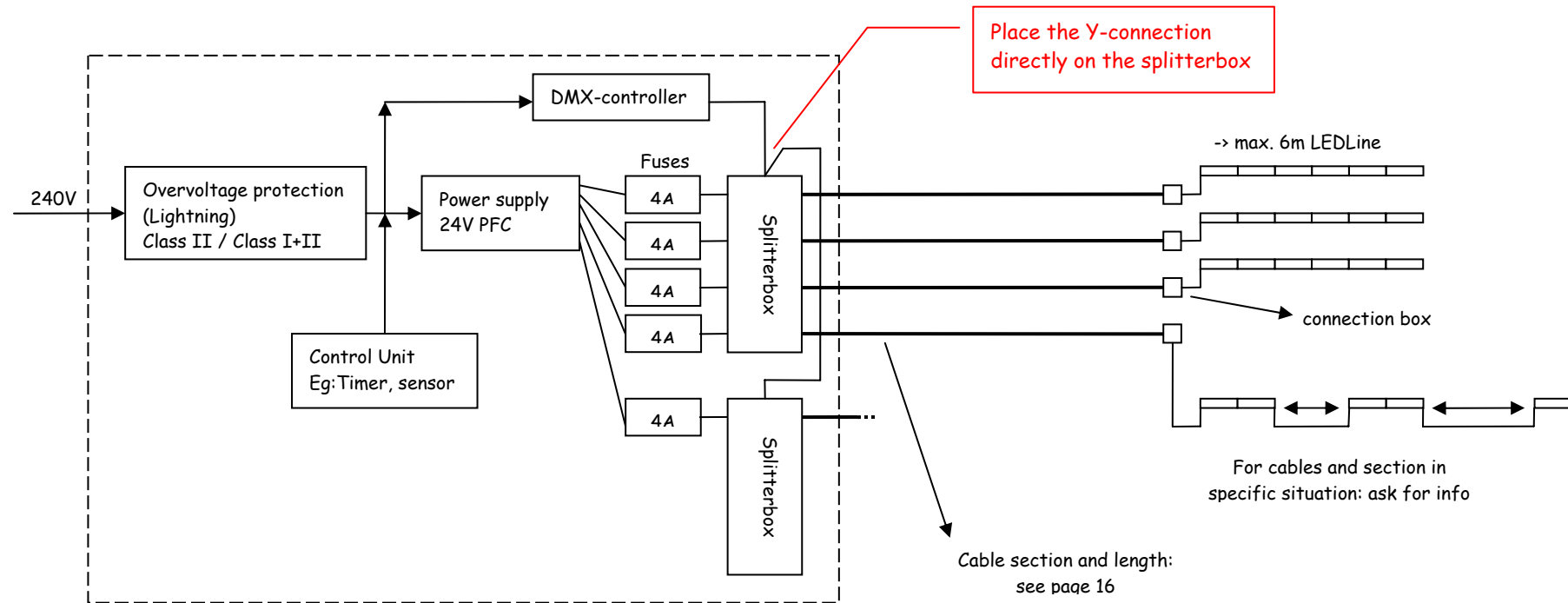

### Positioning:

- ➔ indoors (no precautions needed)
- ➔ outdoors in cabinet:  
Conditioned: temperature and humidity controlled

### 8. 60m LEDline wiring example

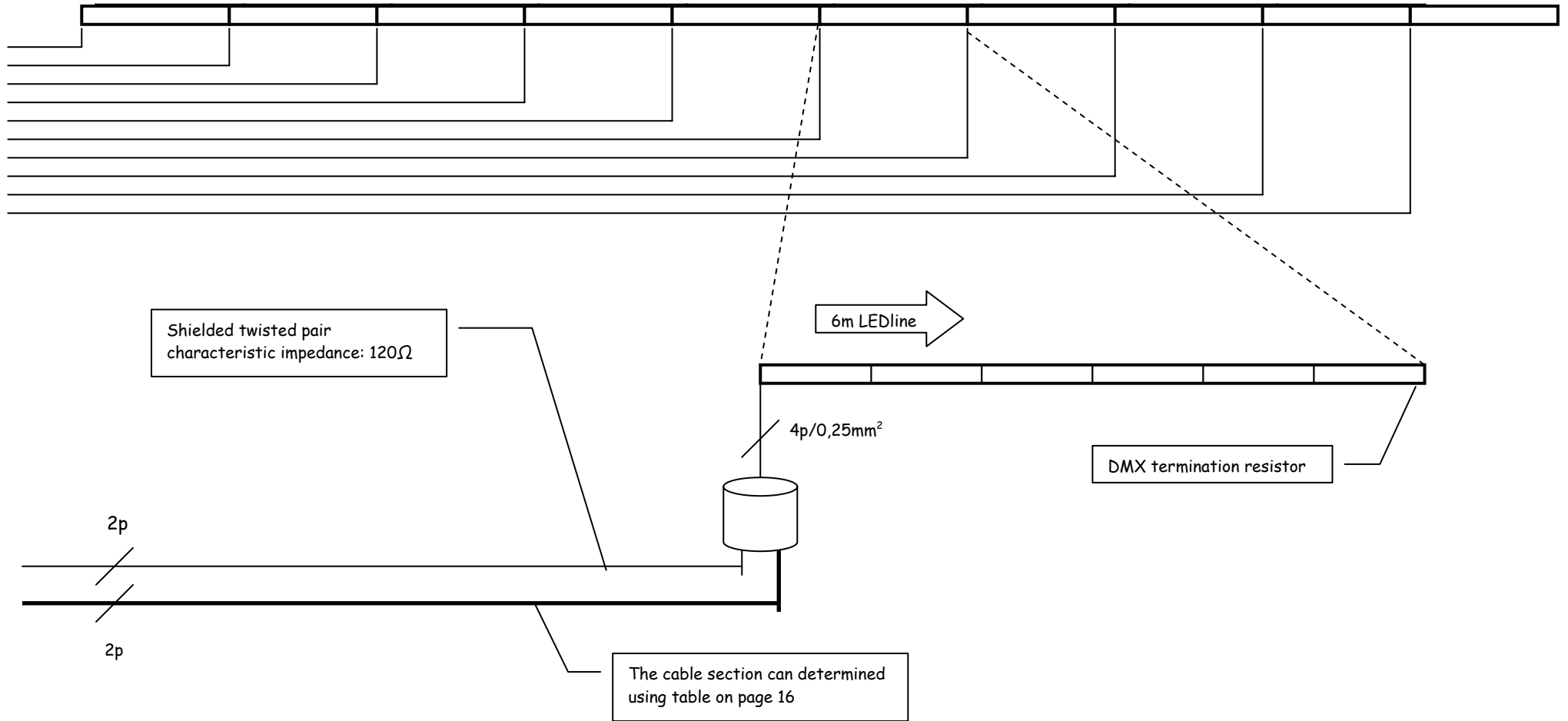

## 9. Accessories

### 9.1. DMX splitter box

A DMX splitter box separates the power supply between different LEDstrings and boosts the DMX signal to each LEDstring.

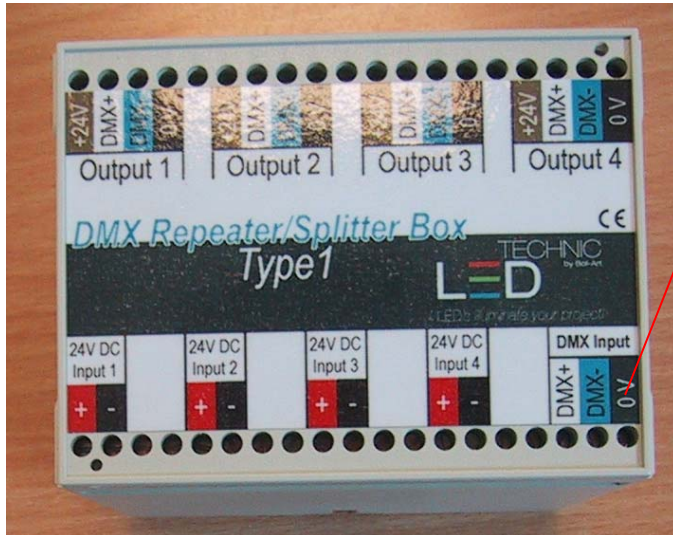

75x100x110mm (L/W/H)

With one DMX splitter box it is possible to drive 24 LEDlines(1000mm).

Do not connect the 0V of DMX input, to prevent damage from equipotential currents

### 9.2. DMX terminator (male)



At the end of each DMX-string a resistor of  $120\Omega$  should be placed.

### 9.3. DMX hub cable (male to male)



(See page 6)

Transmits DMX, blocks power supply.

#### 9.4. Connection cable 5m 4p (Male to Female)



Cable section: 0,25mm<sup>2</sup>

#### 9.5. End plate



The endplate can be glued to each end of the LEDline.  
Two endplates are delivered with each LEDline.

#### 9.6. Endcap (Male or Female)



To protect the supply leads that are not used.

#### 9.7. Adhesive lined tubing



However our connectors are rated IP68, we recommend using cable sleeving in moisture environments.

## 9.8. Power supply



Input voltage 110V-240V

Power	Output voltage	Output current	Specifications	PFC <sup>5</sup>	
25W	22V-27,6V	max. 1,1A		no	Indoor
75W	22,8-26,4V	max. 3,2A		yes	
120W	24V-28V	max. 5A	din-rail mountable	no	
240W	24V-28V	max. 10A	din-rail mountable	yes	
60W	22V-27V	max. 2,5A	IP65	yes	Outdoor
150W	22V-27V	max. 6,3A	IP65	yes	
240W	24,4V-25,6V	max. 10A	IP65	yes	

<sup>5</sup> Power Factor Correction

## 9.9. Mounting rail



The LEDline 'clicks' on a mounting rail.

LEDline length	Supplied mounting rails
500mm	250mm + 150mm
1000mm	500mm + 150mm

(150mm interconnect rail => used to create a continuous LEDline)

Other lengths on request.

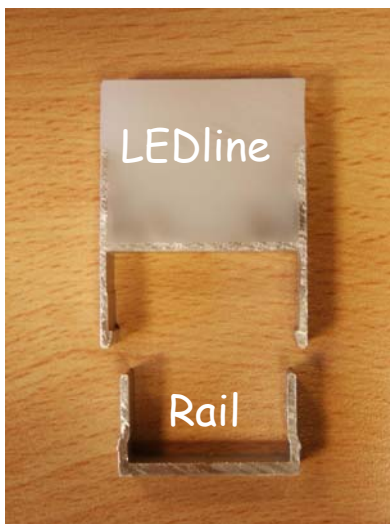

## 10. Standard packaging of a RGB LEDline

Each LEDline is supplied with:

- mounting rail
- interconnect rail
- end plates
- RGB driver

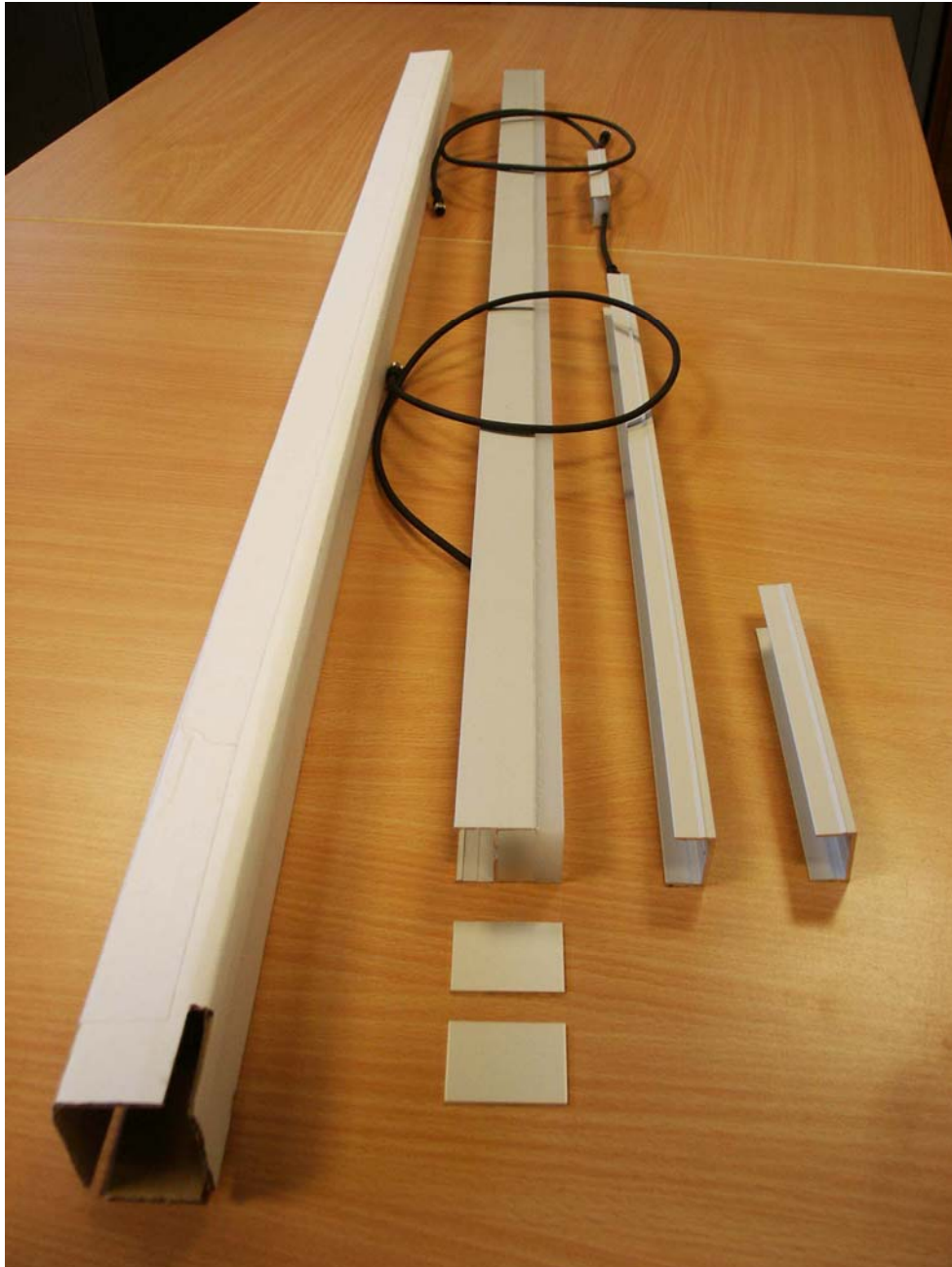

## 11. Electrical Design rules

- Current through the cables may not exceed 4A.
  - Therefore Max. 6 LEDlines(1000mm) can be placed in a string.
  - Each string has to be fused (4A surge fuse).
- The first RGB-driver in a LEDstring has to receive 24VDC.
  - When the distance between the LEDstring and power supply exceeds 5m, you can solve this problem by:
    - Adjusting up the output voltage of the power supply.
    - Enlarging the cable section of the cable (see 8).
- If you want to interconnect more then 6 LEDlines(1000mm), an DMX splitter box has to be used.
- At the end of each DMX line a terminator should be used.

## 12. Inground mounting

When mounting the lightingfixture inground it must be drained, this is to prevent it from frost damage.

When using our LEDline inground we recommend using the LEDdrain system. This system can also drain the water on the pavement.



### 13. Supply cable guidelines

- The following table is calculated for a power supply with an output voltage of 26V. The maximum length is calculated in order to get 24V at the end of the supply cable.

# RGB LEDlines 1000mm	Cable section (mm <sup>2</sup> )	Maximum distance (m)
1	1,5	122,4
2	1,5	61,2
3	1,5	40,8
4	1,5	30,6
5	1,5	24,5
6	1,5	20,4
1	2,5	204,1
2	2,5	102,0
3	2,5	68,0
4	2,5	51,0
5	2,5	40,8
6	2,5	34,0
1	4	326,5
2	4	163,3
3	4	108,8
4	4	81,6
5	4	65,3
6	4	54,4
1	6	489,8
2	6	244,9
3	6	163,3
4	6	122,4
5	6	98,0
6	6	81,6